

RTC CUP Challenge Rulebook

Appendix No. 1. Proving Ground: Description, Technical Features, Configuration.
Three sectors of the proving ground: Maze, Field, Tower.

1. Maze

The Maze allows assessing functional capabilities of a robot in enclosed space and low visibility conditions.

Figure 1 shows the Maze with the dimensions of 4,650x3,880x800 mm. It consists of 30 cells, the dimensions of which are 740x740x740 mm. The Maze has **2 entries**: through the **door** and through the **doorstep**.

The Maze involves various tests, obstacles and tasks to pass on the way to the exit. All tasks in the Maze vary in complexity and passage method, each task employs robot's certain capacities.

Cell quantity and connection order, as well as tasks arrangement, may be changed before the competition.

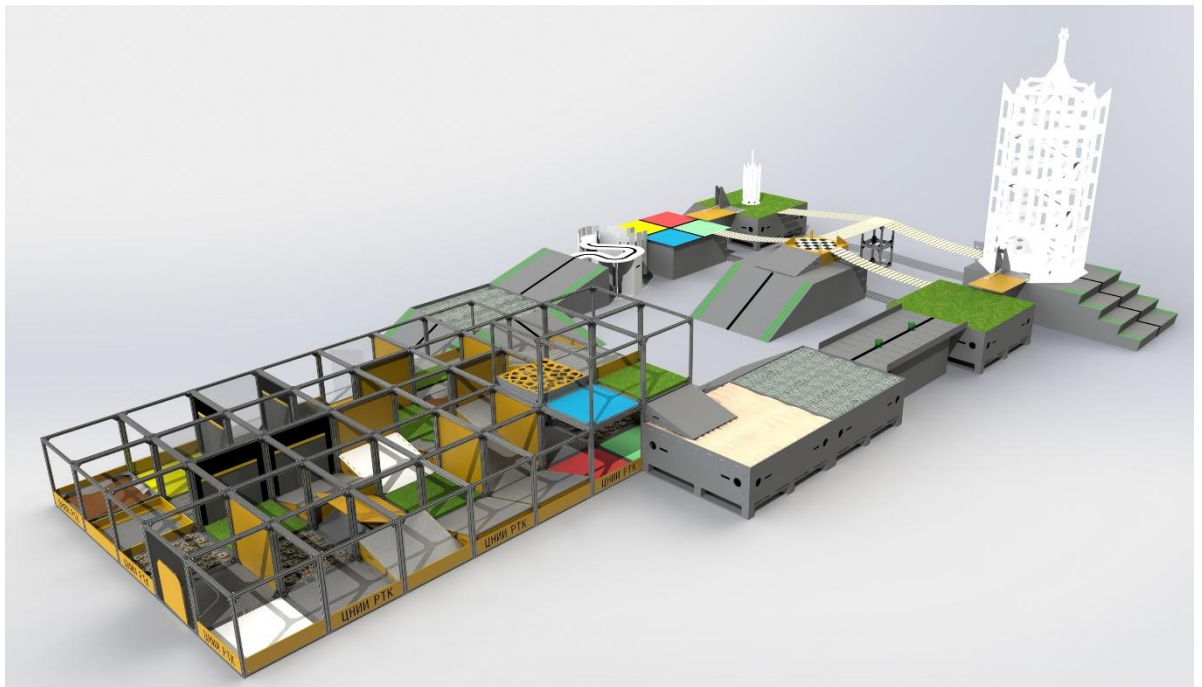

Figure 1.1 Example of the Maze Assembly and Tasks Arrangement



Figure 1.2 the Maze at the Robofinist 2016

Tests and Tasks in the Maze

The **Door** opening both ways 90° (by pulling and pushing) with a bar handle (Figure 2). Door dimensions are $480 \times 480 \times 8$. When pushed by a robot, the door gets blocked by a stopper fixed inside the Maze and is set in an open position at 90° .

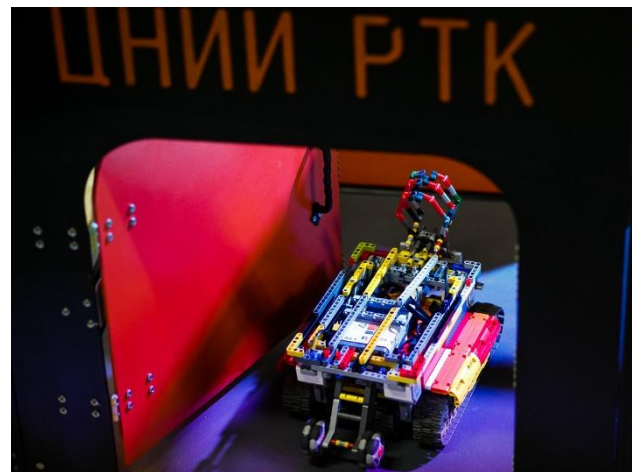
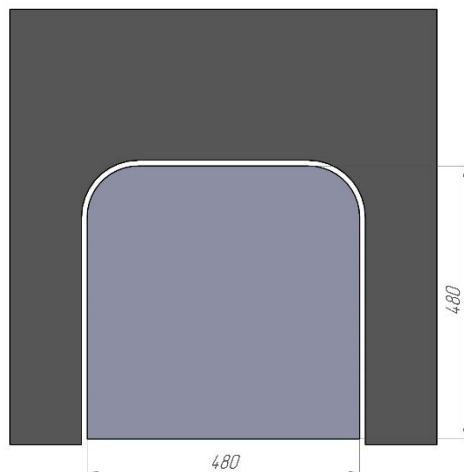

Figure 2. Door

Inside the Maze there may be randomly arranged **Inclined Surfaces** (Figure 4) at 15° slope angle and of $740 \times 690 \times 200$ dimensions.

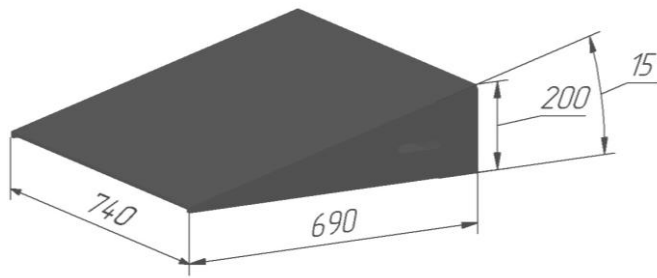

Figure 4. 15°Inclined Surface

The Inclined Surface at 20° slope angle (Figure 5) and of 500x250x100 dimensions is set against boxes.

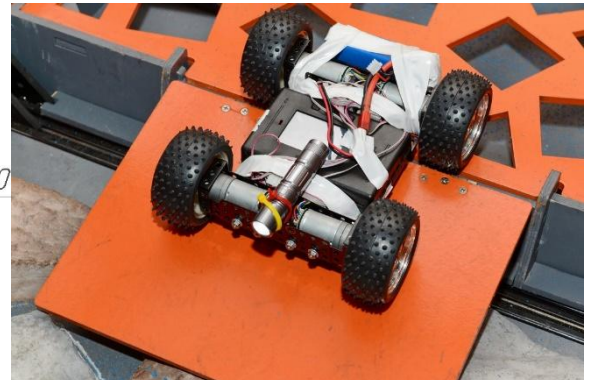
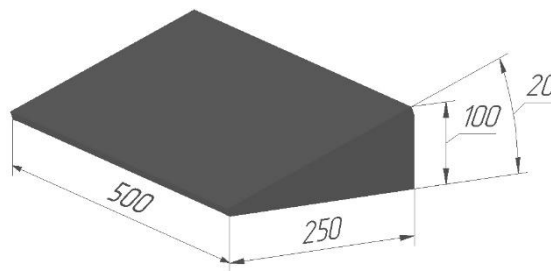

Figure 5. 20° Inclined Surface

Inclined Surfaces are designed to demonstrate the balance of the gravity center and capacity of a roving robot to cross over inclined sectors.

Inclined Surfaces may be combined in different ways: in groups of two or four, with co-directed or differently directed slopes (Figure 5). The capability to cross over such slopes demonstrates the agility of a robot.

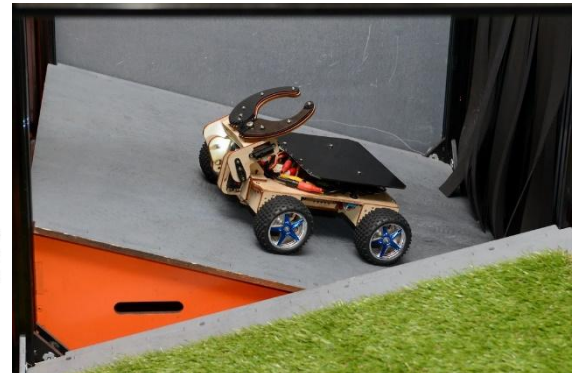
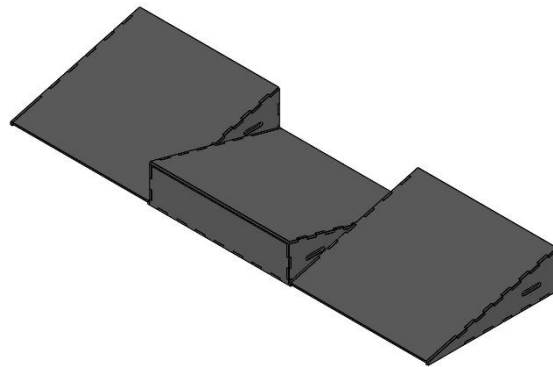

Figure 6. Possible Combination of Inclined Surfaces

Ice is a slippery fluoroplastic plate attached to a plywood sheet (Figure 7). Plate dimensions are 740x740x10. Multipurpose lubricant WD-40 is applied on the surface to increase slipperiness.

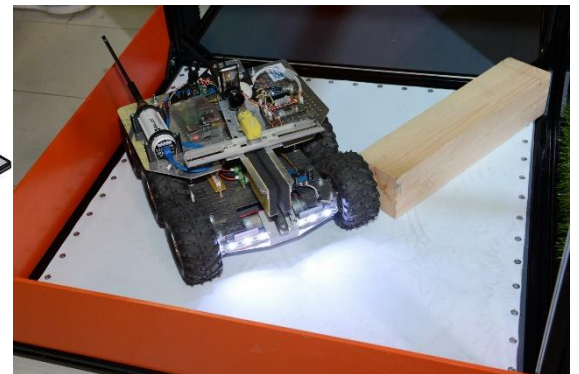
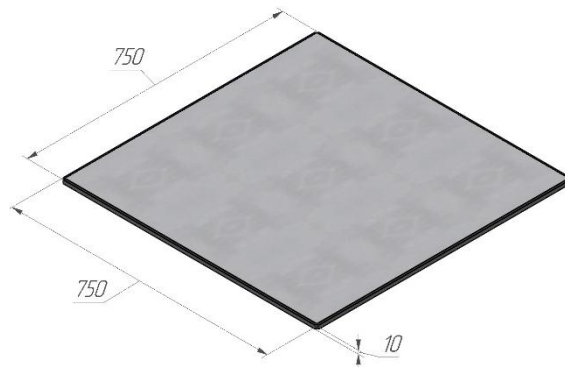

Figure 7. Ice

The **Ice** section is used to test the wheels/tracks traction with the surface. The **Grass** is a sector with artificial grass made of polypropylene, the pile length is 40 mm (Figure 9). The coating is affixed to a plywood sheet. Sector dimensions are 740x740x50.

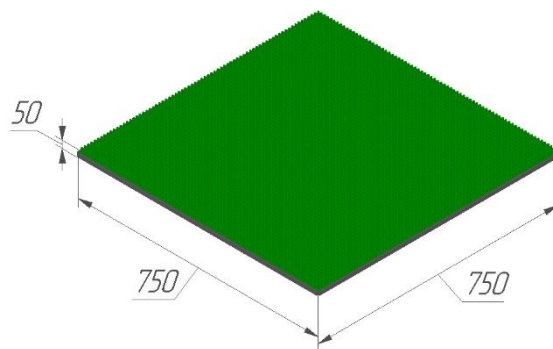

Figure 9. Grass Sector

Artificial grass serves to demonstrate integrity and durability of the robot's structure, as well as its passing ability in the natural environment.

- 1.5.7. The **Stones** sector consists of plywood with pieces of broken stones attached to it. The stone pieces have sharp angles and significantly vary in height (Figure 10). The average height of stone layer is 40 mm. Sector dimensions are 740x740x50.

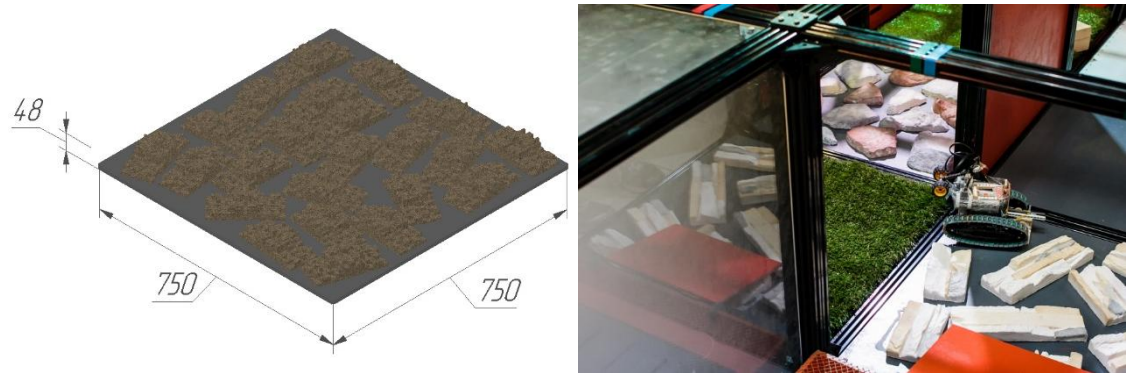

Figure 10. Stones Sector

The Stones sector is designed to demonstrate the robot's passing ability through rough terrain, its engine capacity and suspension load capacity.

The **Sand** sector is a box filled with silica sand fractions of 0.2 - 2.5 mm (Figure 11). Box dimensions are 720x720x30. The height of sand layer varies from 20 to 30 mm. Inclined ramps are mounted inside the box and inclined surfaces are affixed outside the box (Figure 5).

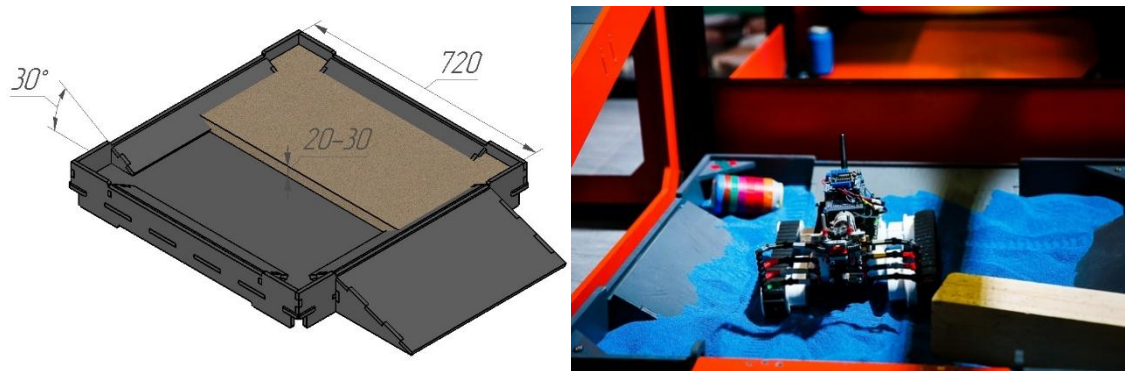

Figure 11. Sandbox

The Sandbox is designed to demonstrate the robot's passing ability through crumbling surfaces, its durability, breakage rate under the external influences typical for a real situation.

The **Ball Pool** is a triangular deepening with two slopes (Figure 12). The deepening is filled with 300 ping-pong plastic balls (40 mm in diameter) and 6 tennis balls (65 mm in diameter). Slopes dimensions are standard: 740x690x200. The depth of balls layer varies from 40 to 100 mm.

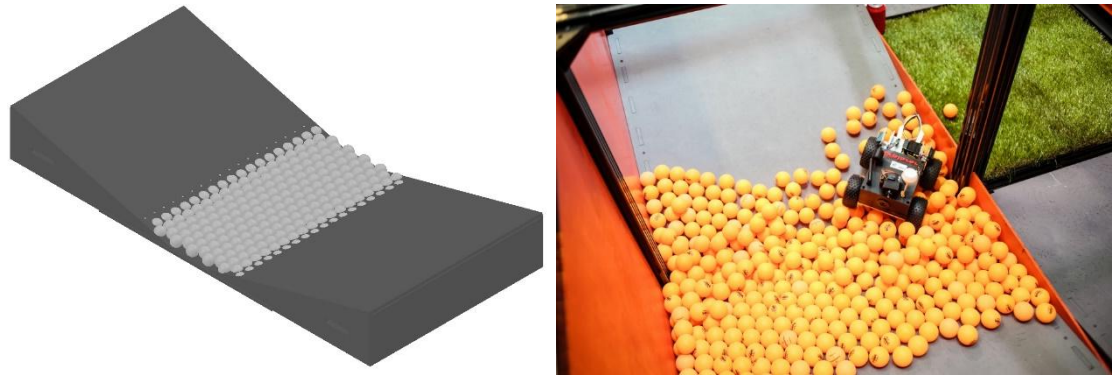
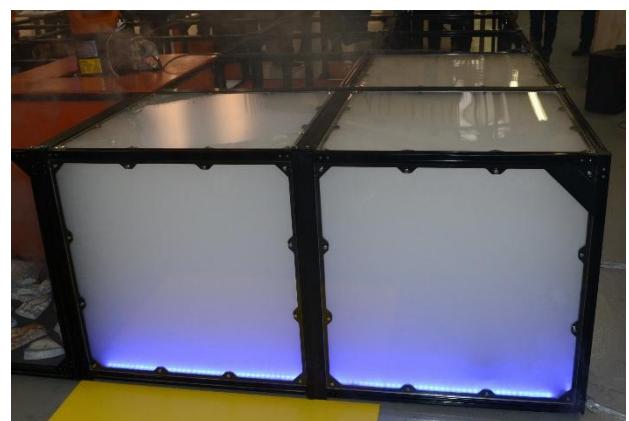
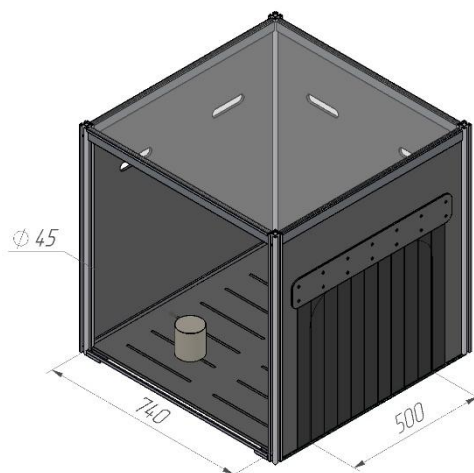

Figure 12. Ball Pool

This sector serves to demonstrate the high passing ability of a robot; this is the most complicated test sector for this parameter on the proving ground. High agility and good robot manipulation skills are also required to pass this task.

The **Fog** sector is filled with intensive fog (Figure 14). It consists of several connected sections (2-3 cells) with a plywood floor (8 mm wide) and transparent plexiglas ceiling. Sections have three “cat door” entrances which are 500x500 arched doorways curtained by rubber strips (50 mm wide). Sections are additionally sealed by mounting adhesive tape. Therefore the smoke penetrates sparingly. Smoke is generated by a smoke machine (standard stage equipment) mounted inside the section (on the floor). Additional obstacles are randomly fixed on the floor of the section: 6-8 plexiglas cans of 100 mm diameter. The minimum travel width between the cans is 450 mm.



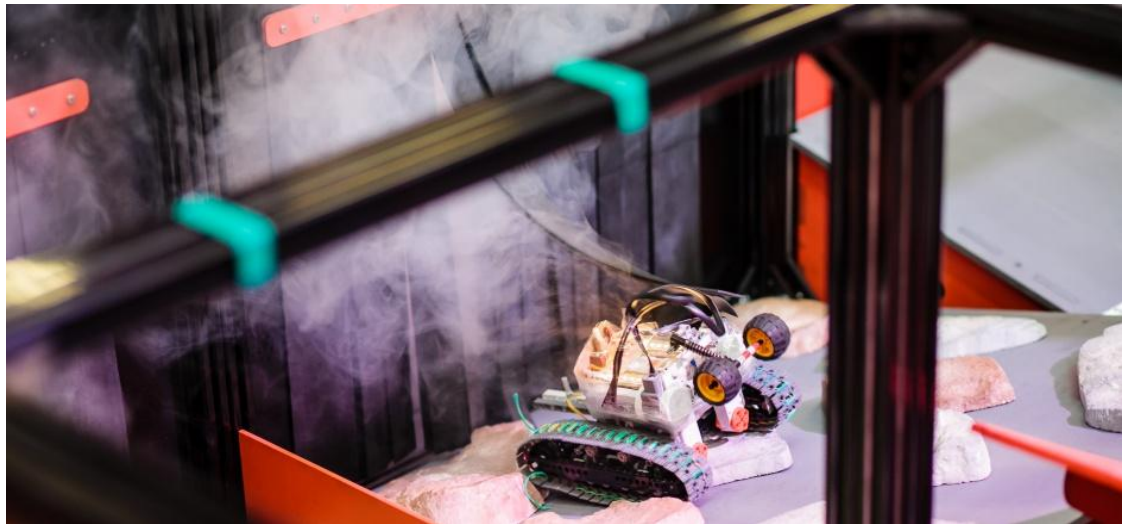

Figure 14. Fog

This sector serves to assess orienteering skills and the robot's agility in limited visibility conditions. Robots may be equipped with flashlights, headlights or other accessories.

The **Button** is a standard switch for a lamp (Figure 16). When switched on, the lamp in the **Fog** sector flashes on. The Button is placed 100 mm above the floor.



Figure 16. Button

Button is used to demonstrate the following characteristics of the robot's manipulator: accuracy, pressure, working range.

Expanded Clay is a sector consisting of a box filled with 10-20 mm fractions of expanded clay (Figure 17). Box dimensions are 720x720x30. The height of expanded clay layer varies from 20 to 30 mm. Inclined ramps are mounted inside the box and inclined surfaces are affixed outside the box (Figure 5).



Figure 17. Expanded Clay

This sector is to demonstrate the robot's ability to pass through crumbling surface. Since the expanded clay is lightweight, the more the robot manoeuvres in a cell, the more it digs into the expanded clay layer.

The **Net** sector consists of 740x740 mm frame with a net stretched on it (Figure 18). Tension is weak and net sags slightly. The mesh size is 1 sq cm. The Net is made of thin kapron cord by knot weaving.

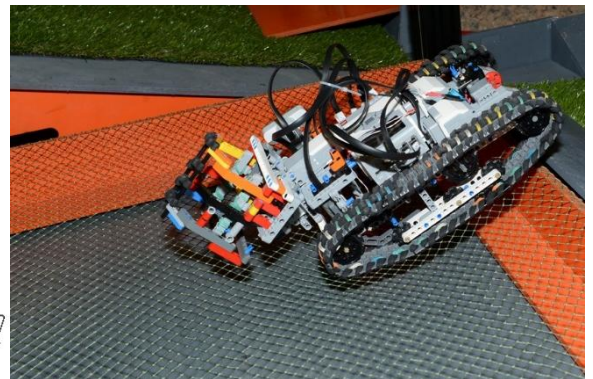
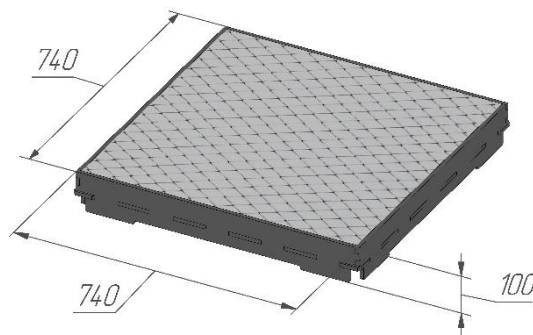

Figure 18. Net

Passing through this sector serves to identify the robot's design defects: protruding and sticking parts, poorly distributed balance. The **Grass Slope** is a typical 15° inclined surface with artificial grass on it. The surface dimensions are 740x690x200 (Figure 19). Pile length is 40 mm. The width of the artificial grass layer may vary from 200 mm to the total width of the slope.

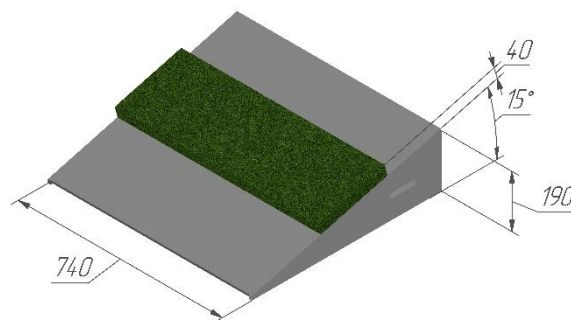

Figure 19. Grass Slope

The passage through such surface demonstrates the traction quality and engine capacity, as well as the robot's capability to cross over inclined rough terrain.

The **Mire** is a polyether bag stowed in the cell and half-filled with polystyrene ballsof 4-6 mm diameter. The bag is pressed by standard 15° inclined surfaces serving as exit slopes. 20° inclined surfaces are attached to the slopes inside for robots to descend to the bag (Figure 20).

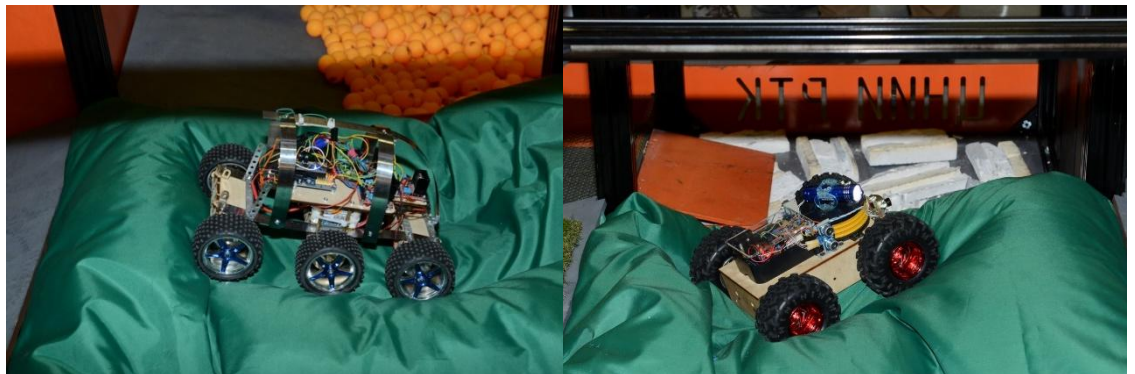

Figure 20. Mire

In this sector the robot can demonstrate its ability to cross over viscous substance with its surface changing in response to the robot's movements.

For the **BeaconsCollection** 0.33 l aluminum cans are used. Cans are painted in one of the following colors: red, blue, green, yellow. The robot's task is to grip and lift the beacon or carry it to the respective color zone in any other way. The color zone is marked with a whole-colored rubberized cloth of red, blue, green, yellow or white color spread on the floor.

Beacons delivery allows to assess accuracy and agility of a robot and functionality of its manipulator.

Possible variation of beacons and zones allocation in the Maze is shown in Figure 21.

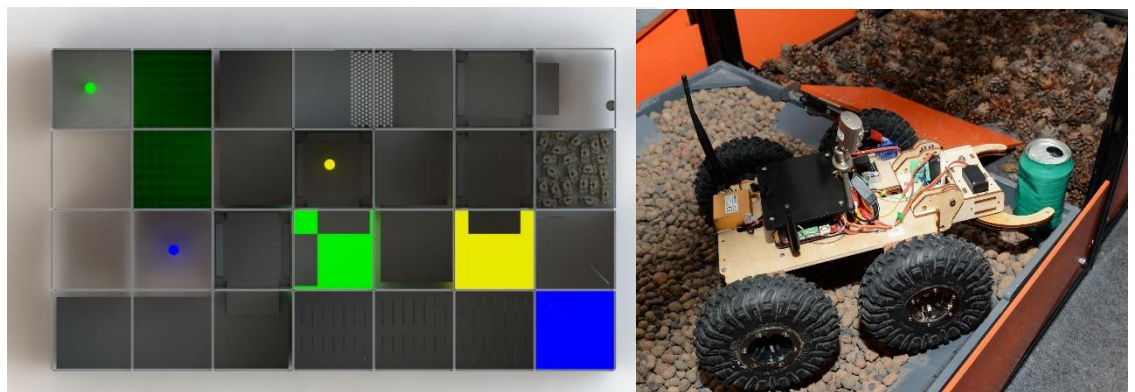

Figure 21. Possible Beacons and Zones Allocation in the Maze

High Beacon is a standard beacon located at an elevation representing a

miniature copy of the Tower: 160 mm in height and 90 mm in diameter (Figure 22).

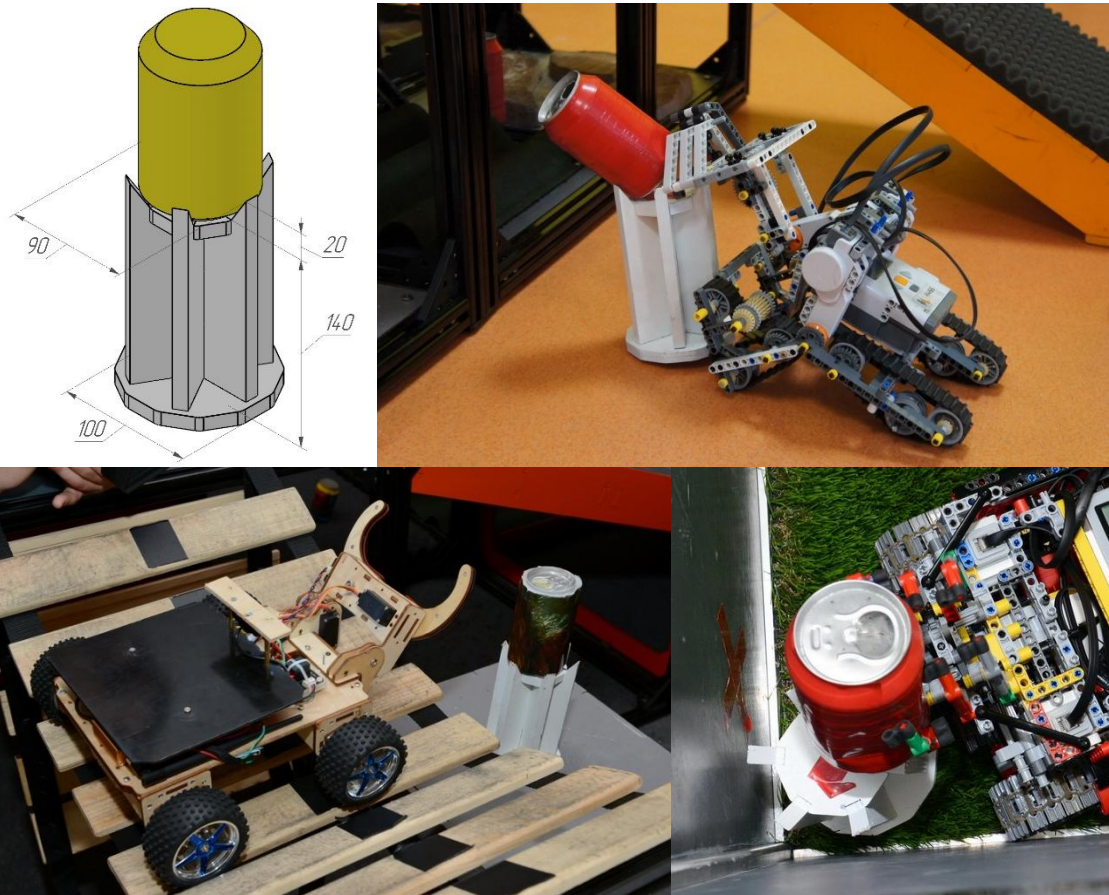

Figure 22. Tower with Beacon

Beacon's displacement from the tower proves the high functionality of the robot's manipulator.

2. Field

The Field is connected with the exits from Maze from one side and with Tower from another. The Field consists of certain details connected in different positions.

There are beacons and zones on the Field, but in a bigger quantity than in Maze.

Certain sectors of the Field have marking (Figures 23 - 25 and 29 - 31).

There are two types of lines on the Field:

- black line in the middle of the element (50 mm wide). Black line requires the robot's autonomous operation.
- 2 green lines at 50 mm from the edge of the field. The lines are 20 mm wide and the distance between them is 50 mm. Green lines along the elements' edges mark the borders for the robots to stick to when moving.

The marking may require the robot's autonomous operation within these sectors.

Field Elements

Figure 23 shows **30° Inclined Surface** with the dimensions of 1500x1075x620 mm and slope angle of 30°.

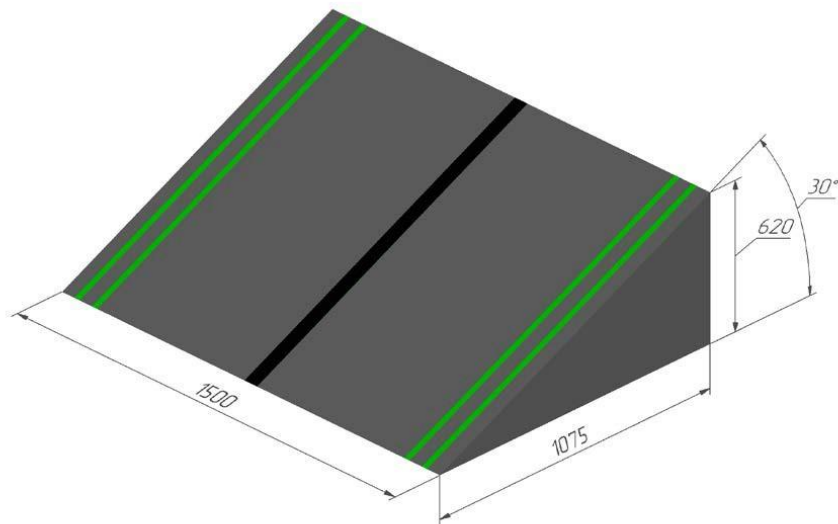

Figure 23. 30° Inclined Surface

Inclined surfaces (Figures 23 - 25) demonstrate the robot's capability to cross over inclined surfaces.

Figure 24 shows **15° Inclined Surface** with the dimensions of 1500x1120x300 mm and slope angle of 15°.

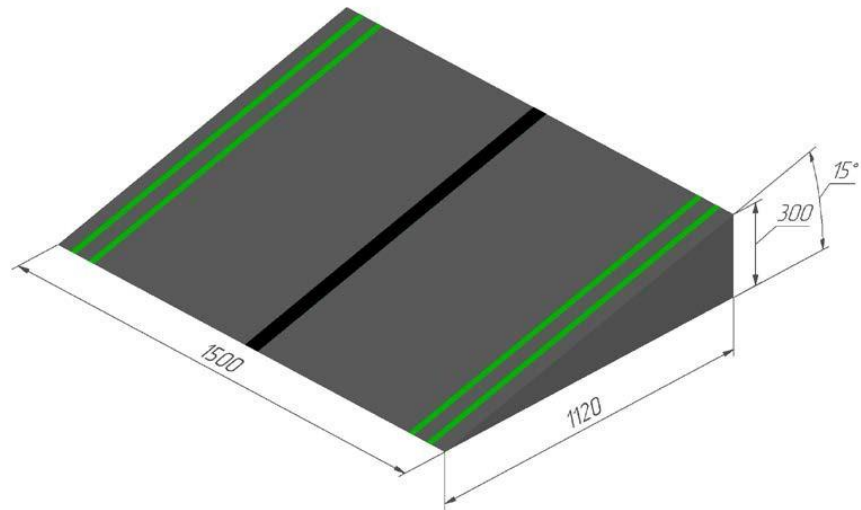

Figure 24. 15° Inclined Surface

Figure 25 shows **15° Midline Inclined Surface** with the dimensions of 1500x1165x300 - 620 mm and slope angle of 15°.

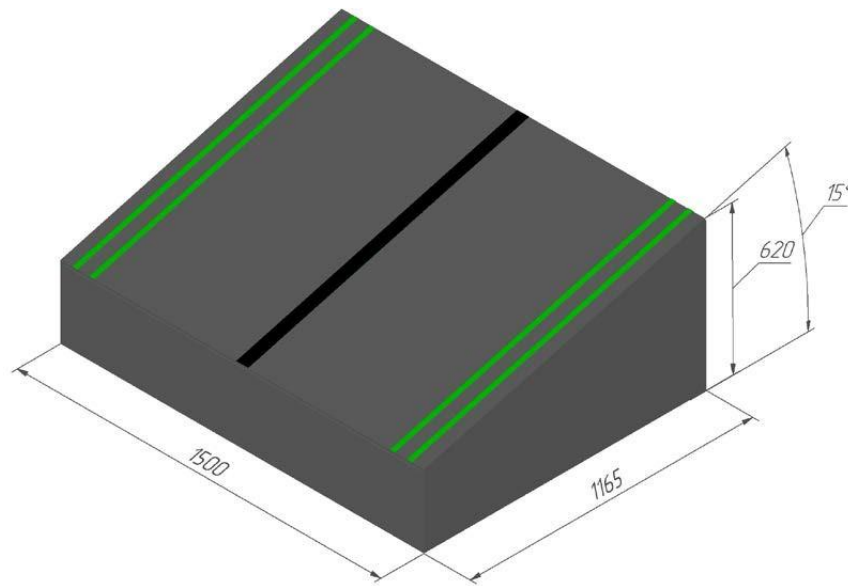

Figure 25. 15° Midline Inclined Surface

Figure 26 shows **35°Inclined Surface** with the dimensions of 1500x850x600 mm and slope angle of 35°.

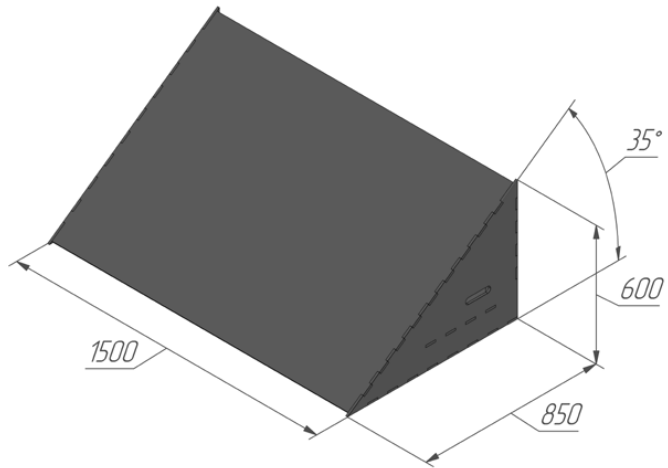

Figure 26. 35° Inclined Surface

Figure 27 shows **45° Inclined Surface** with the dimensions of 1500x600x600 mm and slope angle of 45°.

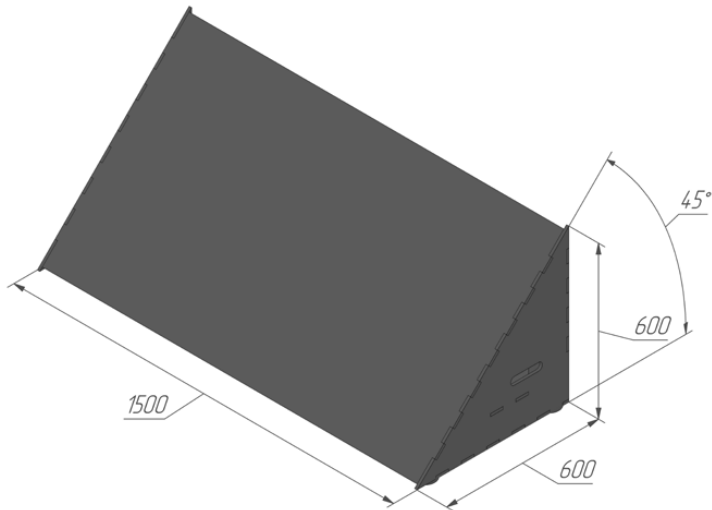

Figure 27. 45° Inclined Surface

Figure 28 shows the **Gravel Sector** with the dimensions of 1500x1490x300 mm. The Gravel Sector is filled to the walls with gravel. Gravel size is 30 mm.

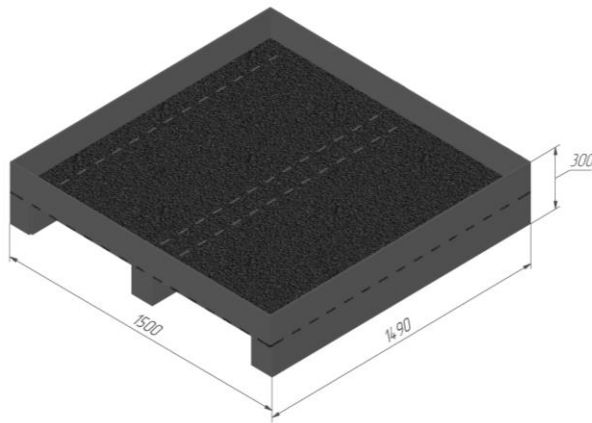

Figure 28. Gravel Sector

Gravel sector is used to assess the robot's capability to cross over rough terrain.

Figure 29 shows the Interbedded Platform with the dimensions of 1500x1500x620 mm.

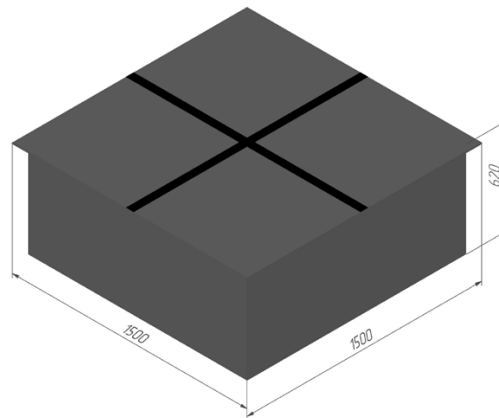

Figure 29. Interbedded Platform

The Interbedded Platform is required to couple the obstacles with each other.

Figure 30 shows the **Staircase** with the dimensions of 1480x1220x620 mm. The steps are 150 mm high and 340 mm wide.

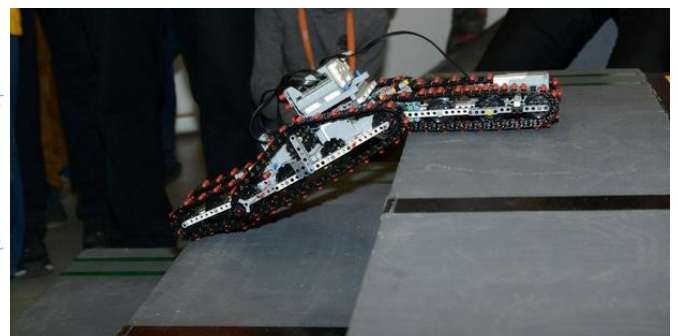
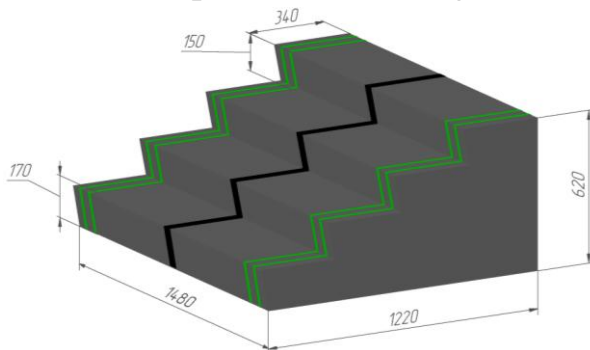

Figure 30. Staircase

The Staircase is to demonstrate and practice the movement of a roving robot through variable geometry surfaces.

The procedure of **Beacons Collection** here is the same as Beacons Collection in the Maze, but the robots do not have to cross over the obstacles in the Field with a beacon in their manipulators.

Possible variation of beacons and zones allocation on the Field is presented in Figure 32.

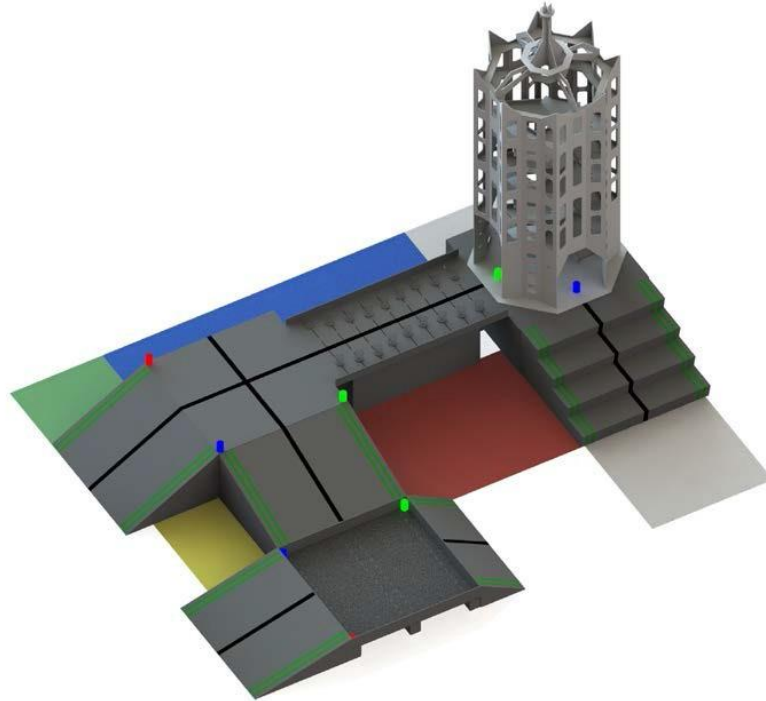

Figure 32. Possible Beacons Allocation on the Field

3 Tower

The **Tower** (Figure 33) is a four level structure with winding passages between the levels. The spiral ascent's width is 210 mm the slope angle is 24° .

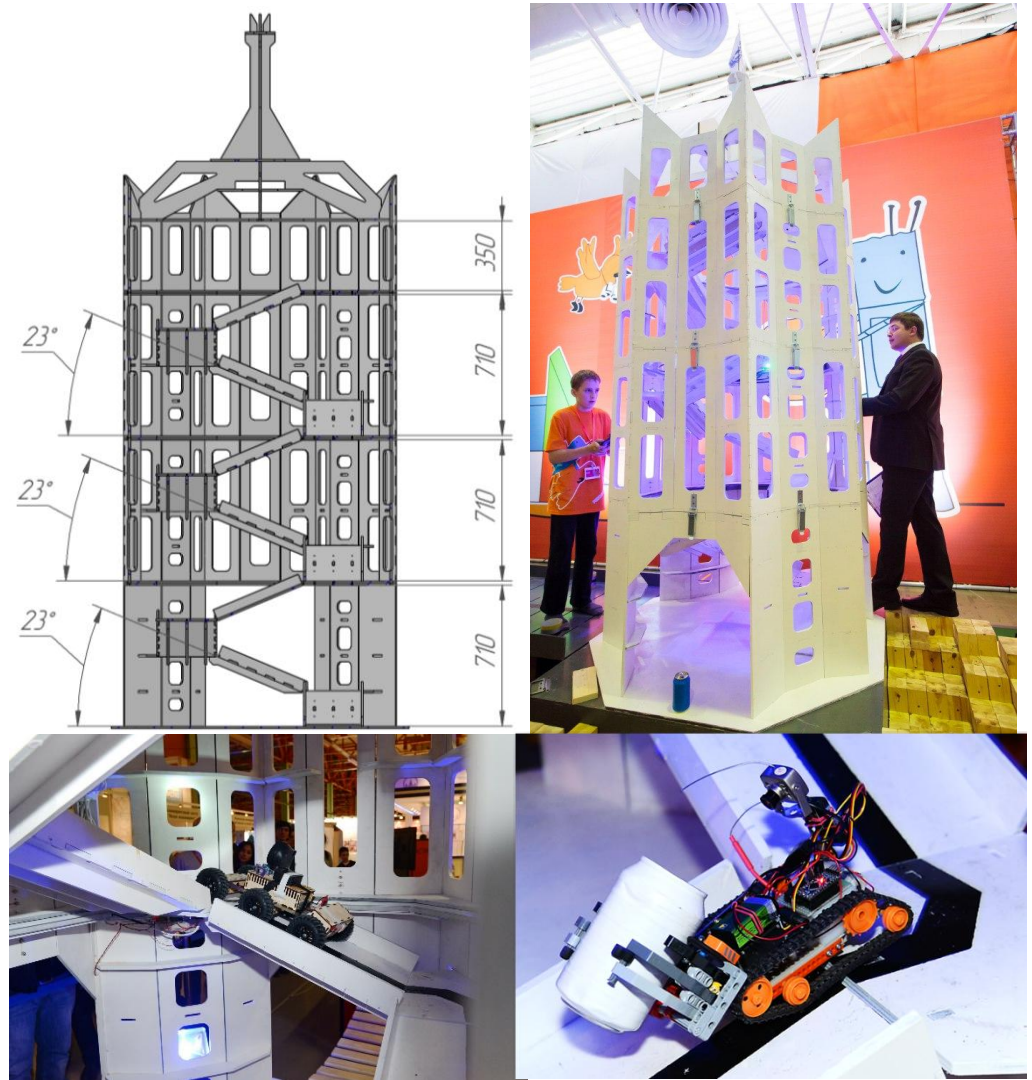

Figure 33. Tower

Tower is required to assess the robot's agility in the limited space and to demonstrate its balance of gravity center and ability to cross over slopes.

The Tower is marked by a black line in the middle of winding entrance to the Tower (50 mm wide). It serves to demonstrate the robot's autonomous movement along the curve.

Tower Beacon is a standard beacon painted with white.

The beacon is placed on the top fourth level of the Tower. This beacon can be delivered if gripped by the robot's manipulator or thrown off the tower; then the robot shall move down and deliver the beacon to the white zone.



4 **Stand Configuration**

The proving ground configuration and obstacles allocation shall be reported on the day of the competition. The final list of obstacles and points given for their passing shall be reported one week prior to the competition start.

Certain details, obstacles and their allocation may be changed directly before the competition due to unforeseen circumstances.